



Powder handling expert

Injector Screw - ID Type



Wastewater Treatment



Water Treatment



Flue Gas Treatment

Injector Screw:

The injector screw transfers or injects dry chemicals into a sludge mixer, slurry tank or gas stream while isolating moisture, heat and condensation from the dry chemical.

The unit replaces rotary airlocks, pinch valves and slide gates.

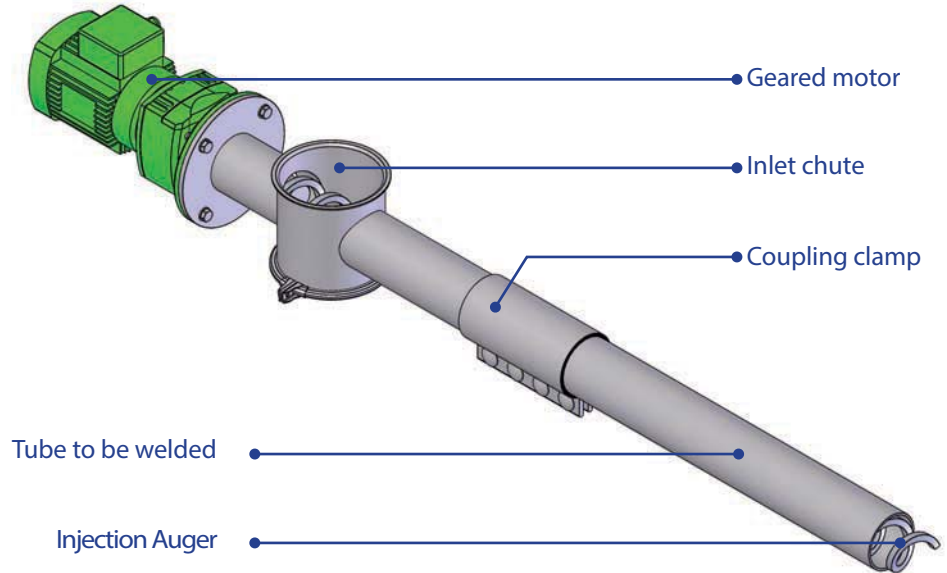

Installation Examples:

Advantages:

- Replaces airlocks/slide gates
- Reinforced screw and geardrive
- Protects the screw feeder and upstream equipment
- Made of SS304
- Easy-to-assemble
- Quick disassembling
- No preventative maintenance

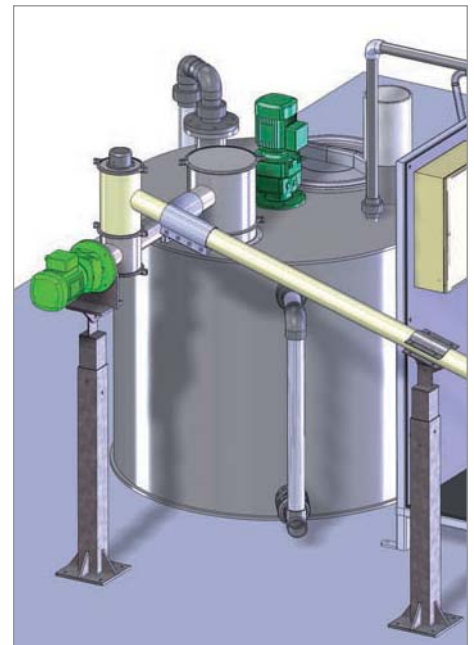
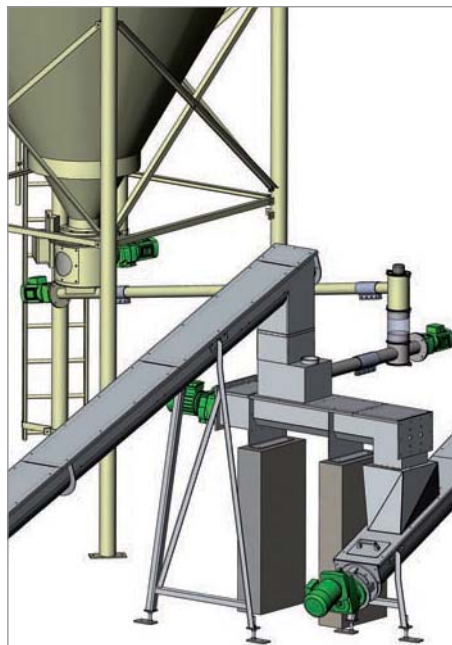



Powder handling expert



Operation:

The injector screw is composed of an inlet chute, a reinforced screw and a geardrive.

The power of the motor is oversized and the screw is reinforced in order to sustain difficult operating conditions generated by moisture, steam or pressure.

The injector scaling prevents lump formation and is capable of handling virtually any dry chemical.



Advantages:

- Fabrication material: stainless steel 304/316
- Can be installed on new or existing equipment



Options :

- Rotation sensor
- Injection box
- Supports

Injector type	Injector outer Ø	Max feedrate*
ID 80	3 ½"	20 ft ³ /hr
ID 100	4 ¼"	45 ft ³ /hr
ID 120	5 ½"	140 ft ³ /hr
ID 150	6 ½"	240 ft ³ /hr

*feedrate may vary according to product and site design